

# Developments in Bulk Material Elevation Technology

## **P.W. Wypych**

Centre for Bulk Solids and Particulate Technologies  
Faculty of Engineering, University of Wollongong  
Northfields Avenue, Wollongong N.S.W. 2522, Australia

## **P. Olds and R. Olds**

Olds Engineering  
78-80 North Street  
Maryborough N.S.W. 4650, Australia

## **R. McIntosh**

Olds Elevator LLC  
12B Park Avenue  
Hudson, New Hampshire 03051, USA

**Summary:** Existing methods of bulk material elevation, such as dilute-phase pneumatic conveying, screw conveying and bucket elevators, can experience a wide range of problems and hazards. A new type of elevator, called the Olds Elevator, has been developed recently to overcome many of these problems. This paper describes and reviews this new technology and demonstrates some its unique features and advantages via industrial case studies. It also describes a new research facility to investigate particular design and operating issues and the future potential of this new technology.

## **INTRODUCTION**

Bulk materials handling plants and processes quite often require the elevation (lifting) of bulk materials to other parts of the plant or process. Numerous technologies and equipment are currently available for this purpose to the designer and practitioner. For example:

- (a) Pneumatic conveyor or air lifter.
- (b) Conventional screw conveyor.
- (c) Bucket elevator.

However, these methods of elevation can experience a range of problems and limitations, such as:

- Pneumatic conveying/lifting: relatively high operating costs (e.g. blower, compressor), product velocities and wear rates (especially for dilute-phase conveying).
- Screw conveying: relatively high operating speeds (due to slippage between the screw flight and particles, and also due to the back-flow of material through the screw flight and casing clearance); increased particle attrition; undesirable casing/screw contact.
- Bucket elevation: relatively high capital and maintenance costs; mis-tracking of belt/chain; damage to belt/chain, buckets and casing. An example of the latter is shown in Figure 1.

The additional problem or hazard with conventional elevation technology (especially bucket elevators) is the increased risk of a dust explosion due to: sparking caused by mechanical damage or impact (e.g. tramp metal, broken bucket, misalignment of belt/chain/screws); ignition caused by overheating bearings/pulleys; frictional heating caused by buckets shearing against product that has built up at the bottom of the bucket elevator casing [1]. This is exacerbated by the dust generation mechanisms and dust clouds that can be prevalent inside such conventional elevators. Some typical sources of dust generation include particle-particle and particle-wall impacts, particle attrition, turbulence and induced/entrained air flows. Another concern is the propagation of a dust explosion or deflagration through the elevator to other parts of the plant, in which case some method of explosion control is required (e.g. venting; explosion detection/suppression; product “isolation” barriers, such as those shown in Figure 2 [2]). A new type of elevator, called the Olds Elevator, has been developed recently to overcome many of the above problems. The main aim of this paper is to describe and review this new technology. Some recent case studies are presented to demonstrate its unique features and advantages.



**Figure 1** Examples of Damage to Bucket Elevator

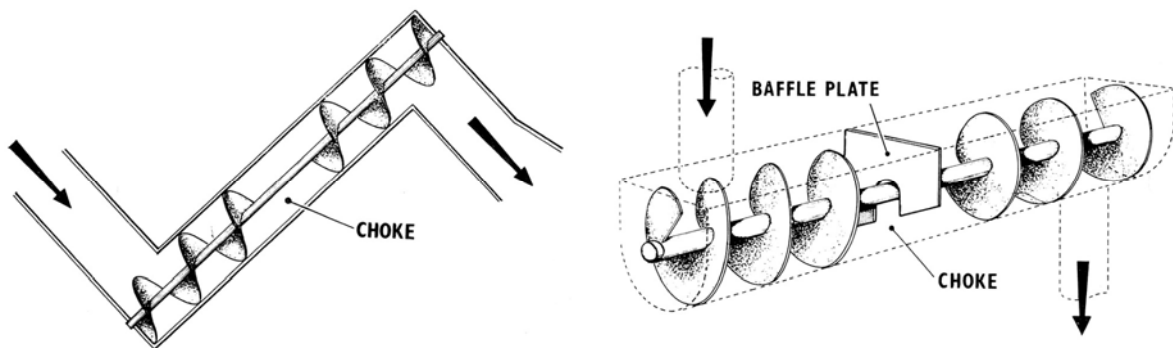

**Figure 2** Examples of Product Explosion Barriers or Chokes [2]

## DESIGN AND OPERATING CHARACTERISTICS

The new vertical elevator design has only one moving part in contact with the bulk material, a tubular casing with attached in-feed scoops that rotates around a static screw. Generous clearance is provided between the static screw and casing, as shown in Figure 3. This clearance is an important design feature that prevents damage to the bulk material, casing wear and metal-on-metal contact. The elevator is self-feeding at a controlled rate as it rotates. Bulk material in the feed hopper typically covers the in-feed scoops. Friction against the inner wall of the casing rotates the material and causes product resting on the screw flight to be driven gently up the inclined face of the screw.

The full-bore flow of material (Figure 4) avoids back-flow or “leakage” of material through the annular clearance, and hence improves “transport” (operational) efficiency. This also helps to stabilise the central position of the screw to inhibit casing contact, and contrasts dramatically with the dynamic “leakage” that takes place in a conventional screw elevator (Figure 5) that offers little resistance to the whirling potential of the rotating screw. Transport efficiency is increased further by the lower slip between the particles and screw flight surface (i.e. compared with a conventional vertical screw conveyor). Due to its full-bore mode of flow, the Olds Elevator also provides an inherent explosion barrier or choke that will prevent explosions or deflagrations propagating to other parts of the plant. It also avoids the high-risk ignition sources that can occur inside conventional elevators, especially bucket elevators.

The in-feed scoops provide a positive, controlled input of material that is volumetrically proportional to casing speed. Hence, the machine can be used as a feed-rate controller, whereas other elevators work as conveyors only and generally need to be fed by another piece of equipment that has to be matched with the loading of the elevator. Furthermore, the Olds Elevator can be operated over an extremely wide range of rotational speeds and hence, turn-down ratios. Also, the flow of material through and from the Olds Elevator is always smooth and steady, without the pulsations experienced with conventional screw conveyors and bucket elevators. This steady mode of flow is gentle to the product and hence, minimises particle damage and dust generation (even when handling fragile particles).

The bottom bearing and shaft seal (necessary in a conventional screw elevator) are eliminated. Bearings are not in close proximity with the agitated product. Dust and valuable plant space are minimised. At all points, bearings are totally external to the product flow and accessible for maintenance, if required. With no seals or bearings at the discharge, the elevator is well suited to handling difficult hot, abrasive or corrosive bulk materials.

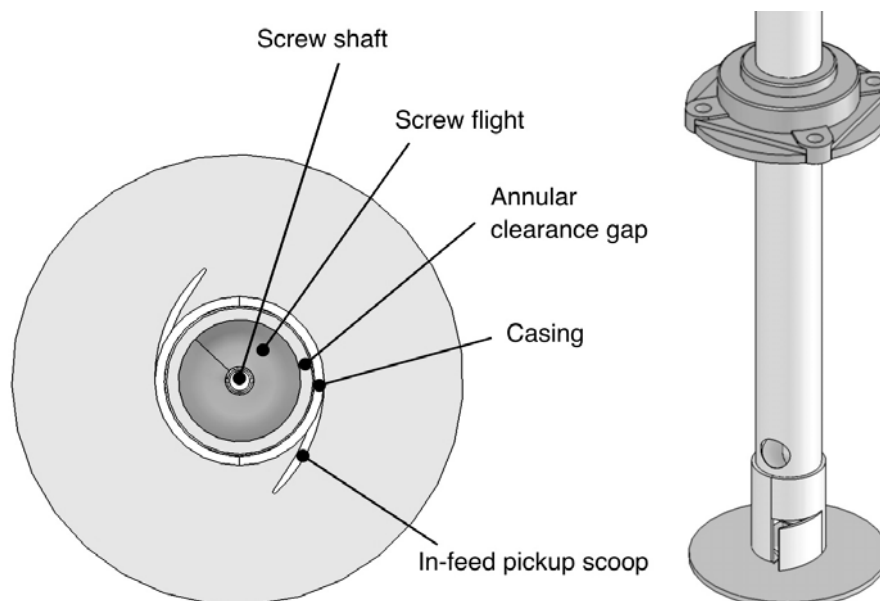

**Figure 3** Olds Elevator showing In-Feed Scoops and Annular Clearance



**Figure 4** “Full-Bore” Flow of Material in an Olds Elevator Demonstration Unit

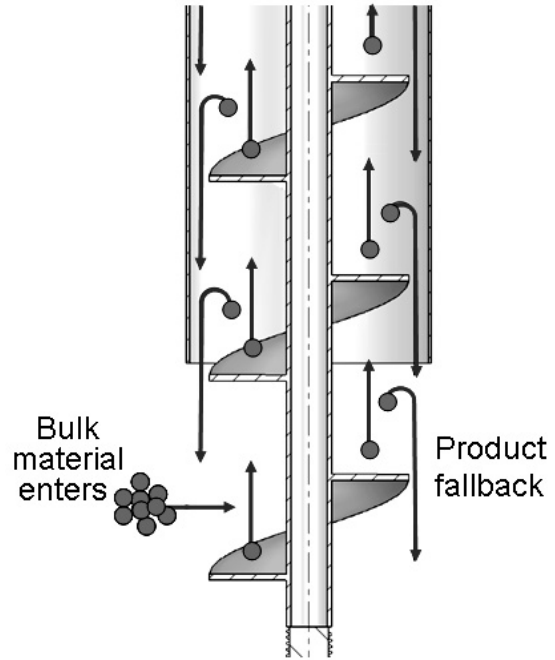
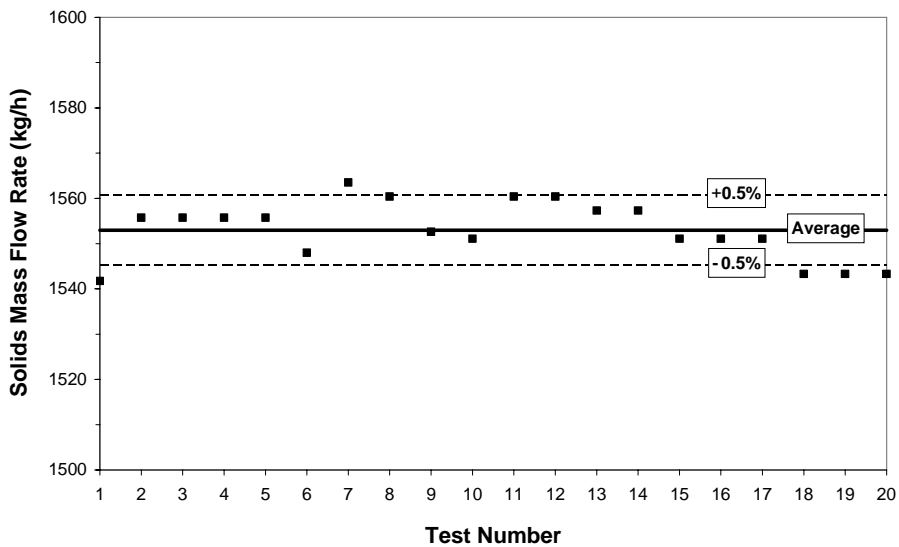

**Figure 5** Back-Flow of Material in a Conventional Vertical Screw Conveyor

### FEED RATE CONTROLLER

Due to its steady and non-pulsatile nature of flow, the Olds Elevator also has the potential of not only elevating but also accurately metering the flow of granular and powdered materials, over a wide range of turn-down ratios. Some preliminary flow rate repeatability results obtained on sulphur pastilles are shown in Figure 6, where a standard Olds Elevator was run at a nominal speed of 70 rpm. With some design enhancements, more accurate flow rate results are expected.

The following industrial case studies are described to further demonstrate the features and advantages of this new technology.



**Figure 6** Olds Elevator Repeatability Test on Sulphur Pastilles at 70 rpm

## CASE STUDIES

### (a) Foundry

In 2003, Mr. Peter Olds was faced with the task of elevating sand to a new moulding machine in his foundry at Olds Engineering in Maryborough, Queensland. He soon discovered that traditional elevators fell short of meeting his objectives of an economical, compact, simple and trouble-free machine. After some brainstorming and prototyping, Mr. Peter Olds invented, developed and installed the very first Olds Elevator, as shown in Figure 7. He soon realised the many features and advantages of this novel type of elevator and quickly patented his device to allow its future application to other products and industries.

### (b) Beans and Grains

In 2004, Bean Growers Australia (BGA), Australia's largest bean processors sought to replace three troublesome bucket elevators that were deployed to feed various sorting, grading and packaging units with five inclined belt conveyors. The Kingaroy facility ultimately replaced its three bucket elevators with two Olds Elevators, saving thousands of dollars in capital costs and recovering significant floor space at their plant (see Figure 8). Each elevator was fitted with a variable speed drive to control the flow rate. A large reduction in the ambient noise level of the plant was also realised. The two Olds Elevators were both 150 mm N.B. (nominal bore), one 7 m high and the other 7.5 m high.



**Figure 7** Original Olds Elevator installed in Olds Engineering Foundry



**Figure 8** Two (2) × 150 mm N.B. Olds Elevators at BGA

**(c) Carbo Ceramics Inc., New Iberia, Louisiana U.S.A.**

Carbo Ceramics is a manufacturer of ceramic products with plants in the USA and China. Their primary product is ceramic beads, which are used as proppants in the oil production industry. These proppants are spheres of ceramic material ranging in size from 300 to 900  $\mu\text{m}$  and are used deep below ground in oil and gas wells. To increase production the oil producing zone around a well is fractured to produce new channels for oil to flow into the well. Ceramic proppants are pumped into the newly-created fractures to prevent the earth from collapsing and closing the fractures. The spherical shape of the proppants allow oil and gas to flow through the proppants and into the well.

Carbo Ceramics manufactures about 20 different grades of ceramic proppant for different applications and requirements. After production, the material is stored in FIBCs, each with a capacity 1,500 kg. The product is shipped from their plants in bulk trucks or bulk rail carriers. When loading the FIBCs into bulk trucks, Carbo Ceramics had historically used a bucket elevator (see Figure 9). When they changed from 1 proppant grade to another they had to spend more than 2 hours cleaning the bucket elevator to avoid cross-contamination between grades. They later added a cleated belt conveyor (see Figure 9) to fill trucks and reduced their clean-up time to 1.25 hours between grades. The bucket elevator was then designated for use with a single proppant grade to avoid timely and costly clean-outs.

In February 2007, Carbo Ceramics installed an Olds Elevator, with an inline sampling device, to load their ceramic proppant beads into trucks (see Figure 10). Clean-up time between grades was reduced to 10 minutes. The loading rate of the 200 mm N.B. Olds Elevator was 35  $\text{t h}^{-1}$ .

**FURTHER RESEARCH**

To investigate in more detail the performance characteristics of the Olds Elevator, a new test rig has been designed and installed at the University of Wollongong. Two modes of operation are possible with this new research facility: recirculation mode (see Figure 11) with a sight glass to demonstrate the mode of flow; test mode, where a separate feed bin on load cells is used to supply material to the Olds Elevator feed hopper and a separate receiving bin on load cells is used to collect the conveyed material and also confirm the actual throughput. Other important operating conditions, such as electrical power and rotational speed, also are measured. This research facility is being employed to investigate particular design and operating issues (e.g. bulk materials subjected to various rotational speeds; wall friction effects; in-feed scoop designs; screw flight designs). It is also being used to explore the future potential of this new technology, in terms of products and industrial applications.



**Figure 9** Bucket Elevator and Cleated Belt Conveyor used originally by Carbo Ceramics



**Figure 10** New Olds Elevator installed at Carbo Ceramics

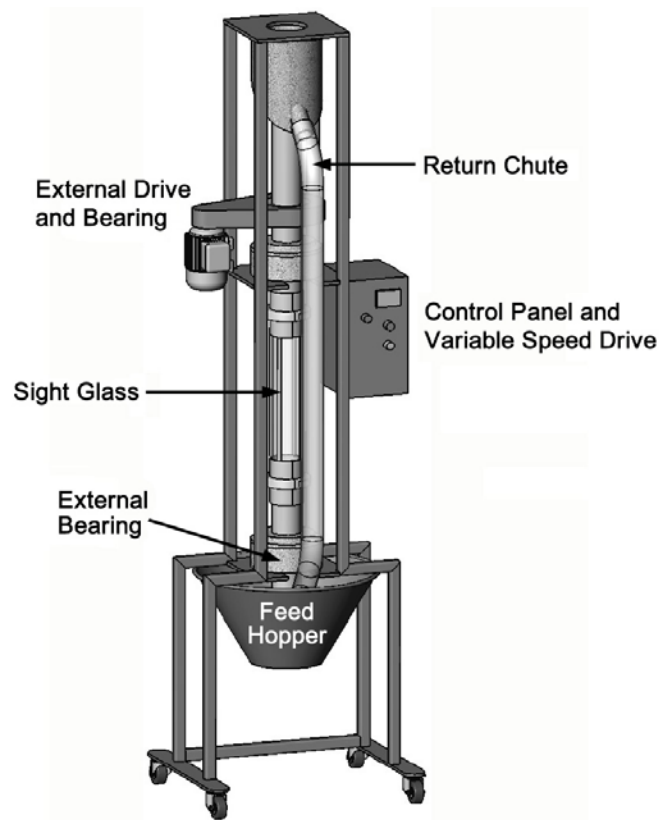

**Figure 11** New Olds Elevator Research Facility installed at University of Wollongong (showing recirculation mode of operation)

## CONCLUSIONS

A new type of elevator, called the Olds Elevator, avoids many of the problems being experienced by traditional bucket elevators, screw conveyors and pneumatic conveyors. Due to its full-bore mode of flow, transport efficiency is greatly improved and explosion ignition and propagation hazards are inherently avoided. The externally mounted bearings minimise maintenance costs and allow the elevator to handle difficult, hot, abrasive and/or corrosive bulk materials. The relatively large clearances between the screw and casing and the relatively low slip velocities between the particles and screw flight help to minimise particle damage and hence, dust generation. The new research facility at the University of Wollongong is being used to investigate in more detail the performance characteristics of the Olds Elevator, as well as the future potential of this new technology.

## REFERENCES

- [1] AS/NZS4745, Code of practice for handling combustible dusts, Standards Australia and Standards New Zealand, 2004.
- [2] Eckhoff, R.K., Dust Explosions in the Process Industries, 2<sup>nd</sup> Edition, Butterworth-Heinemann, U.K., 1997.